

Manifolds & distribution.

Screw & lock: the easiest way to assemble a manifold.

radiant heating
& cooling
components

OEM



Composite manifold SL 1"

The easiest way to assemble a manifold:
just screw & lock

Modular distribution manifold made of glass fibre reinforced polyamide. The manifold is modular to be easily adapted to the length and number of connections they serve. The modification does not involve the use of special tools and can be done on site by simply locking or unlocking the individual modules of the manifold. The hydraulic seal is ensured by generous internal double O-rings.

The pre-assembled modular supply and return manifold realized in reinforced polyamide, including:

- manual intercepting valves with micrometric flow regulator for each circuit
- load/drain cock
- manual/automatic air vent
- supply flowmeter 0-5 l/min for every circuit / AFC valve
- main flow and return thermometers 0-60°C
- wall and cabinet fixing brackets
- piping connections 3/4" eurocone
- main piping connections 1 1/4" M / 1" F

Maximum operating temperature: 75°C

Minimum temperature: 10°C

Maximum working pressure: 6 bar



Benefits

- lightweight and robust manifold made of reinforced polyamide
- ideal for heating and cooling
- the easiest way to assemble a manifold: just screw & lock
- ready to mount actuators
- installation without special tools
- slim design (depth 80 mm)
- modular: possibility to add and remove single modules
- safety first: integrated safety clips to assemble your manifold
- insulated by integrated air chambers
- internal insulated pipe outlets
- all the components are sealed by double internal O-rings
- reversible: main connection left or right as desired on installation site
- room labelling clips

Temperature cycling test

Test method for the resistance of mounted assemblies to temperature cycling
5000 Cycles, temperature 95°C – 20°C , pressure 6 bar, compliance with EN 12293.



Modular: possibility to add and remove single modules



Reversible: connection left or right

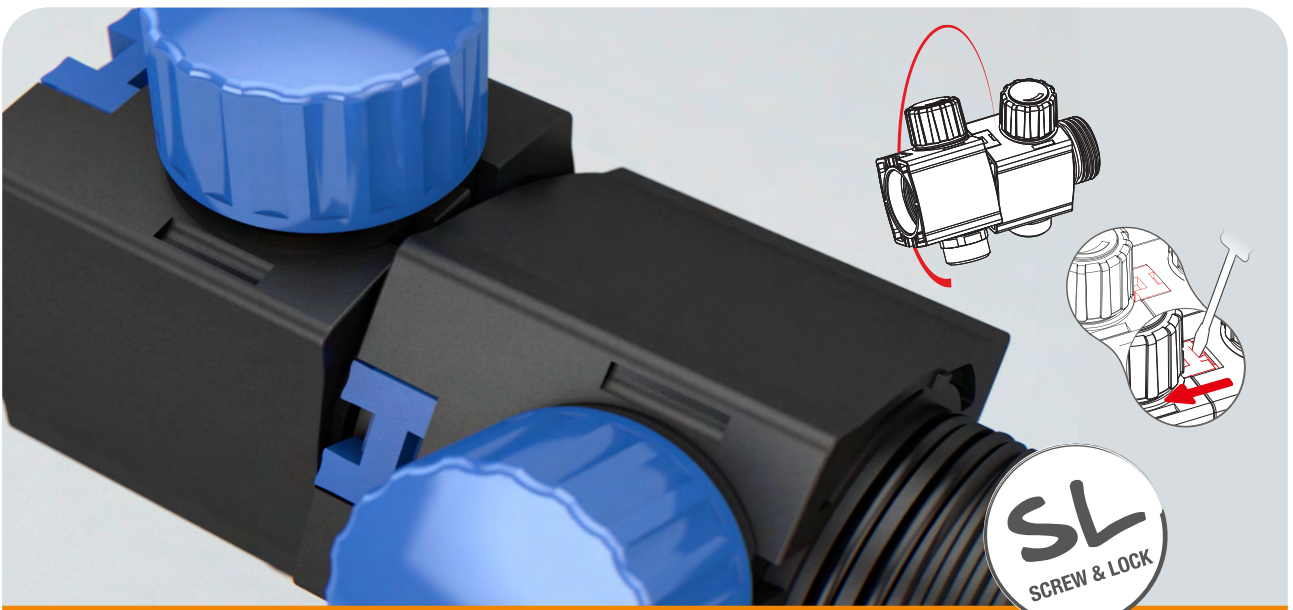

Easy installation: just screw & lock



Room labelling clips

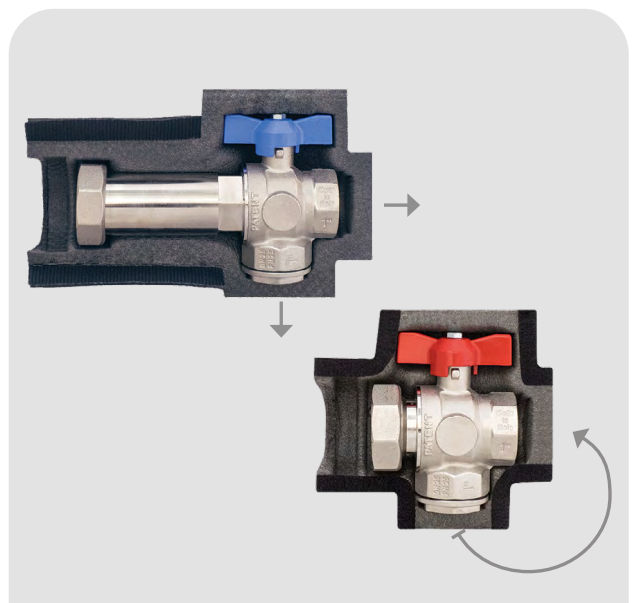

Insulated valves

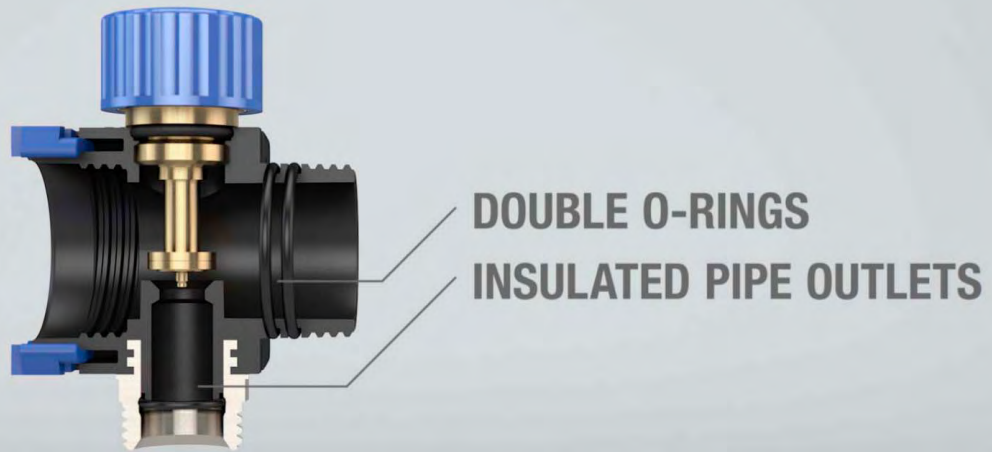

Double O-rings: all the components are sealed by double internal O-rings

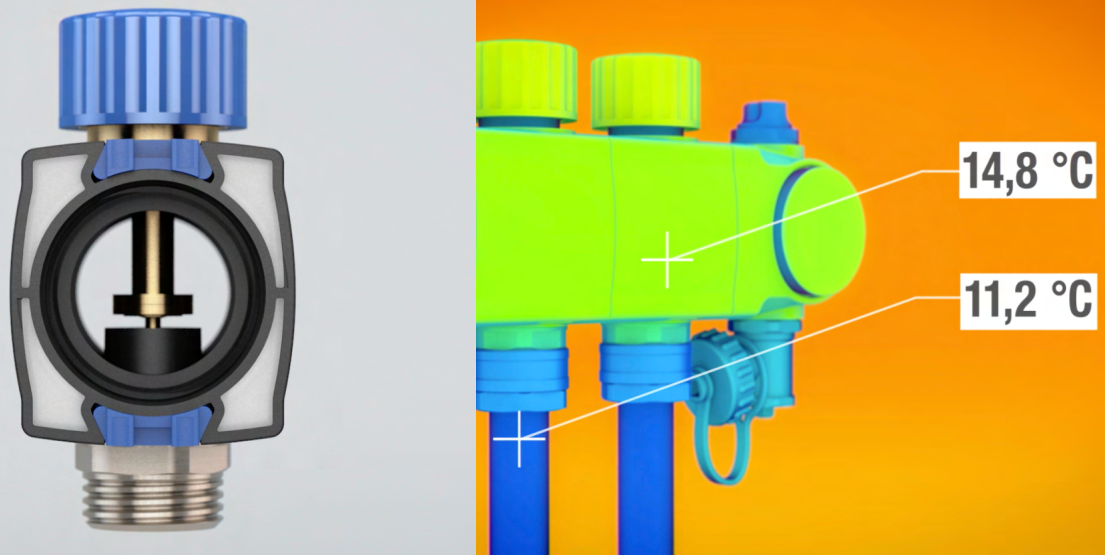

Self-insulating through integrated air chambers

Always insulated

The SL collector encloses an inner tube that thermally insulates each module. This avoids unnecessary heat loss caused by low winter temperatures and condensation problems in summer when the radiant system is in cooling mode. Thanks to a specially designed PE shell, the insulation does not stop at the collector body, but also extends to the ball valves.

SL MANIFOLD - TOP



Modular supply and return manifold realized in reinforced polyamide, with easy installation thanks to the screw and lock system, including: manual intercepting valves with micrometric flow regulator for each circuit, load/drain cock, manual or automatic air vent, supply flow meter 0-5 l/min for every circuit, main flow and return thermometers, wall and cabinet fixing brackets. Individual modules are made from glass fibre reinforced plastic material. Resistant to corrosion and aging self-insulating through integrated air chambers. Pre-arranged for mounting actuation heads on each circuit.

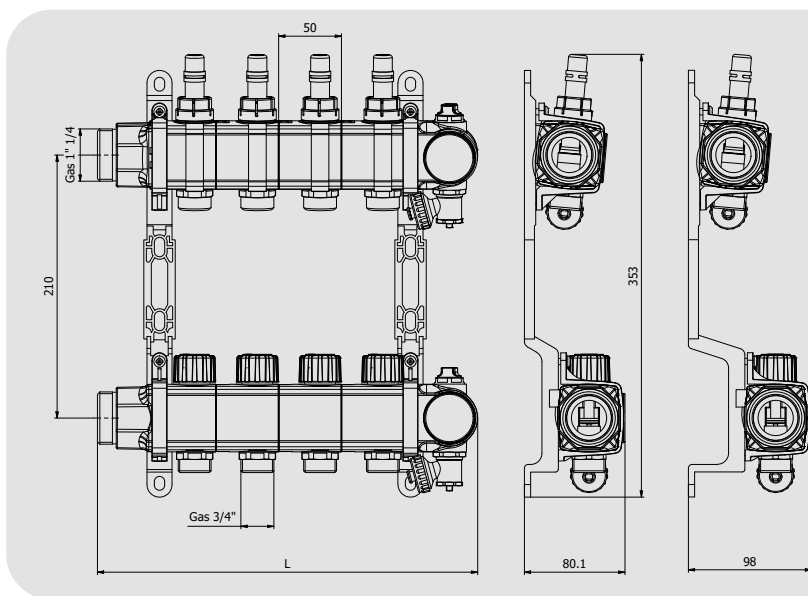
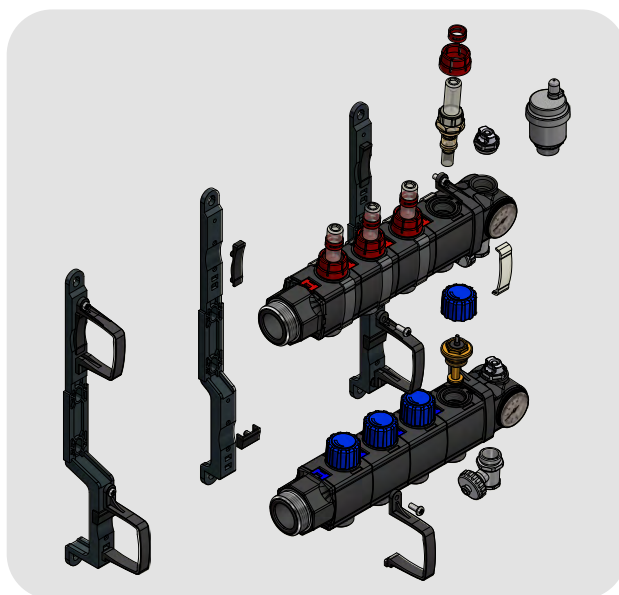

Modules	L	Brackets
1+1	153	2
2+2	203	2
3+3	253	2
4+4	303	2
5+5	353	2
6+6	403	2
7+7	453	2
8+8	503	2
9+9	553	2
10+10	603	2
11+11	653	3
12+12	703	3
13+13	753	3
14+14	803	3
15+15	853	3

AFC flow indicator

Flat brackets

Elevated brackets

Eurokone

Main connection module union nut 1"

Main connection module 1 1/4" M

Innovation meets different customisations.

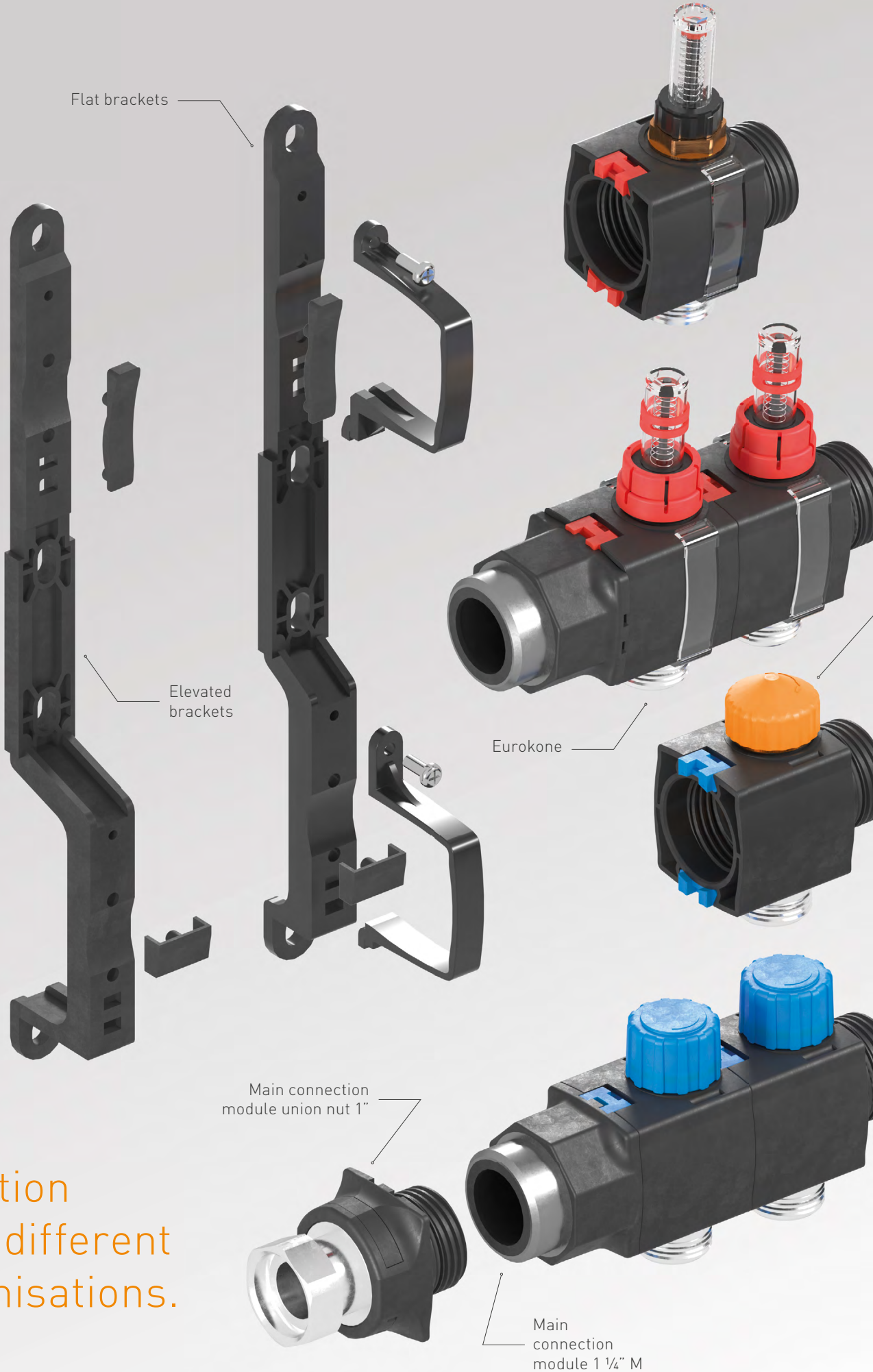

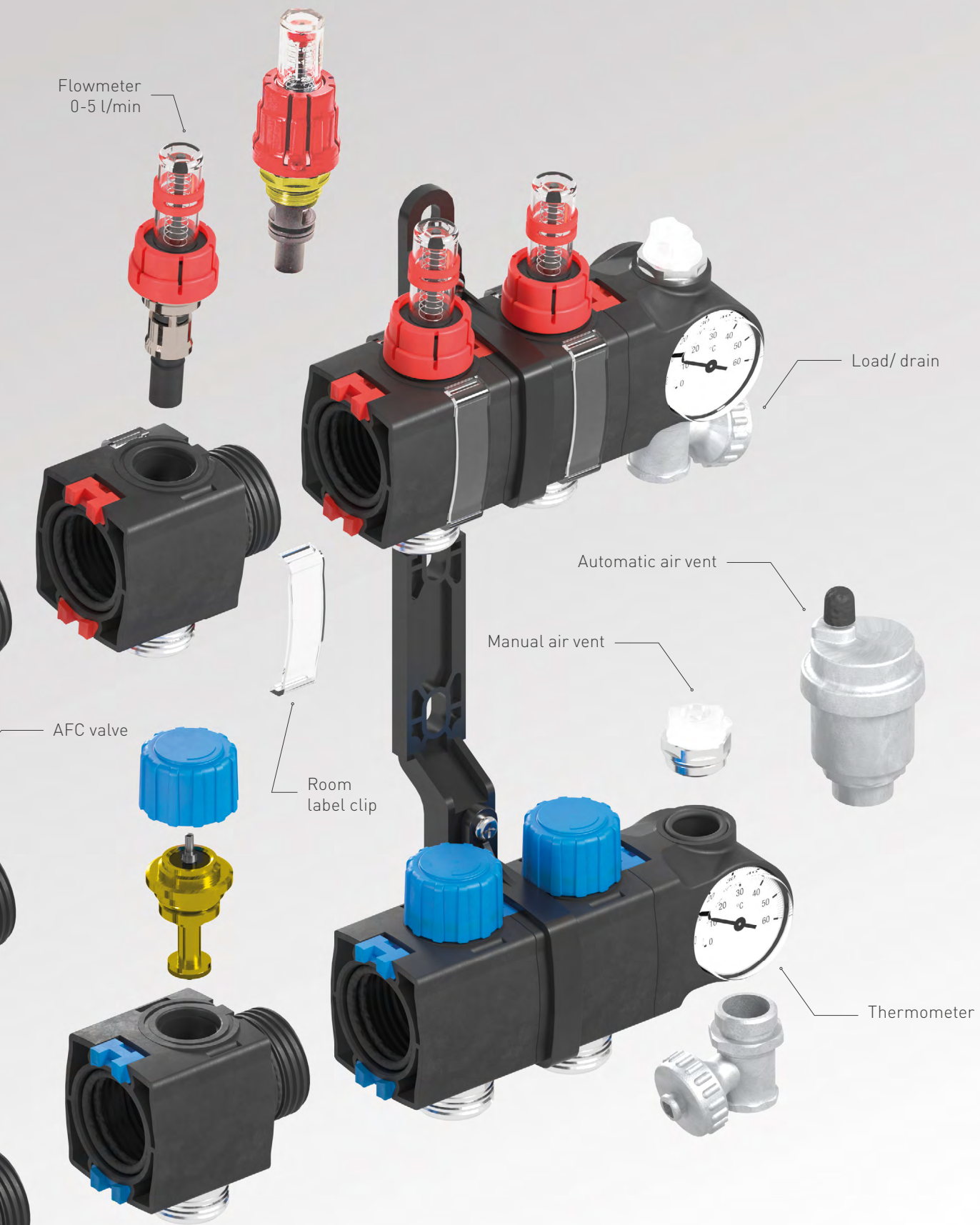

PACKAGING OPTIONS



OEM CUSTOM OPTIONS



SL MANIFOLD - AFC



Modular supply and return manifold realized in reinforced polyamide, with easy installation thanks to the screw and lock system, including: IMI – AFC valves for each circuit, load/drain cock, manual or automatic air vent, flow indicator for every circuit, main flow and return thermometers, wall and cabinet fixing brackets. Individual modules are made from glass fibre reinforced plastic material. Resistant to corrosion and aging self-insulating through integrated air chambers. Pre-arranged for mounting actuation heads on each circuit.

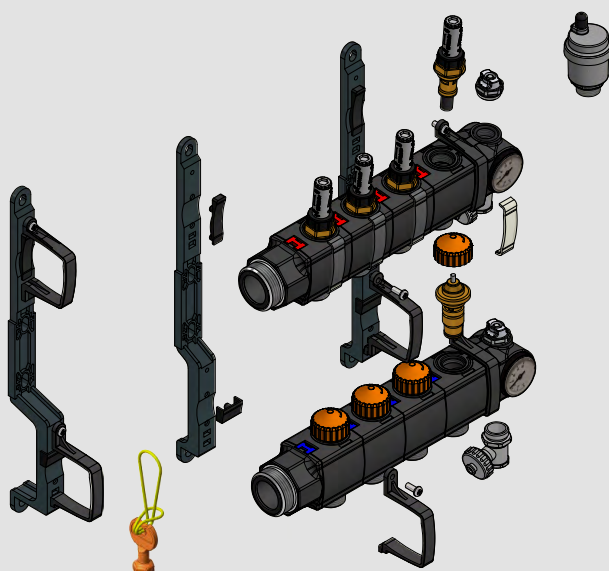

Modules	L	Brackets
1+1	153	2
2+2	203	2
3+3	253	2
4+4	303	2
5+5	353	2
6+6	403	2
7+7	453	2
8+8	503	2
9+9	553	2
10+10	603	2
11+11	653	3
12+12	703	3
13+13	753	3
14+14	803	3
15+15	853	3



Manifold equipped with innovative AFC technology

AFC technology eliminates the time-consuming and complex configuration of systems for maximum efficiency, because you simply select the recommended setting and then let the technology do the system balancing!

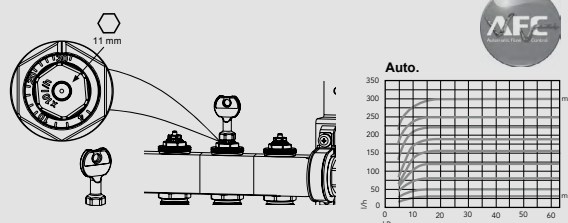

ACCESSOIRES SL MANIFOLD

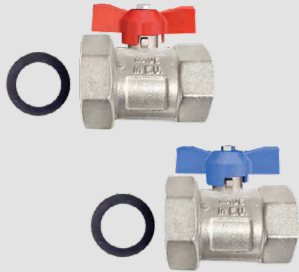

Set of straight valves SL with handles

Set of straight outlet valves, made of nickel-plated brass, with 1" F main connection and 1" 1/4 swivel nut to connect the SL manifold; each valve with handle (red/blue) to open and close the valve. L = 60 mm

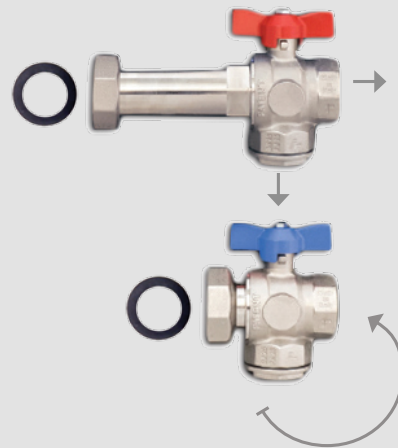

Set of straight/angled valves

Set of angle and straight usable ball valves, made of nickel-plated brass, with 1" F main connection and 1" 1/4 swivel nut to connect the SL manifold; including: red and blue handle to distinguish supply and return connection, brass cap with O-ring for closing the unused connection. L = 145 mm
Optional: flow long, return short

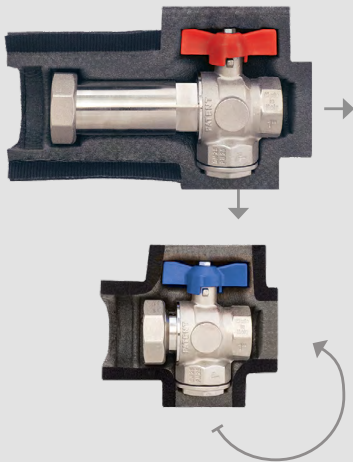

Set of straight/angled valves including PE insulation covers

Set of angle and straight usable ball valves, made of nickel-plated brass, with 1" F main connection and 1" 1/4 swivel nut to connect the SL manifold; including: red and blue handle to distinguish supply and return connection, brass cap with O-ring for closing the unused connection, insulation caps made of preformed PE to completely cover the ball valves. L = 145 mm. Optional: flow long, return short.

4 pipe adapter module

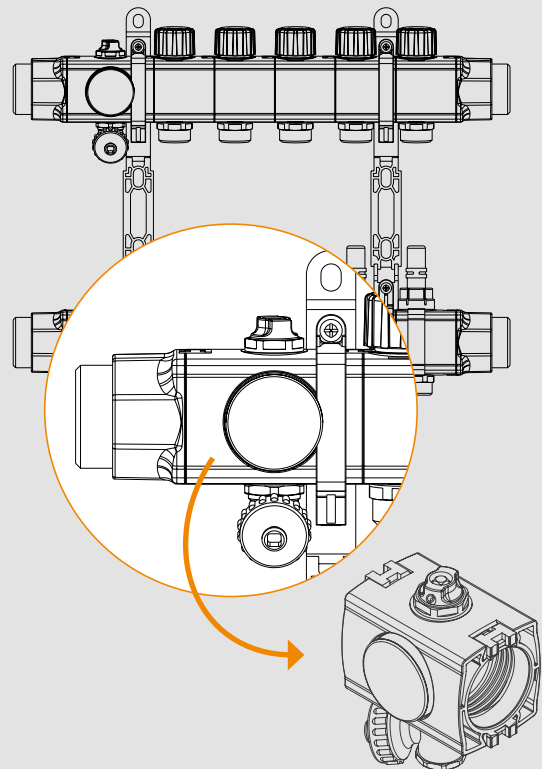

ELITE

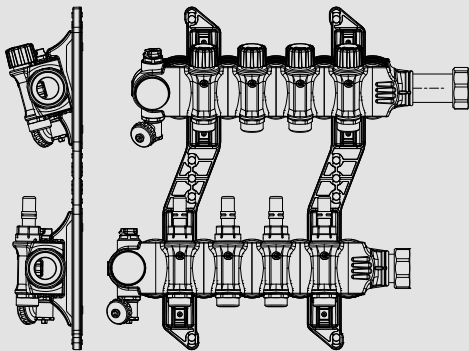

Modular Manifold Elite 1 1/4"

Preassembled modular output/return manifold in reinforced polyamide. Ready for mounting the actuators on every circuit. 1" 1/4 GAS. The manifold is made up of several modules for every single circuit. The modules can be easily assembled without using special tools or specific components which fit only for a certain manifold length, allowing the plumber to modify the number of attachments even on site. Several inserts facilitate the modules fixing, since they have the same graphic continuity of the manifold, giving a structurally compact manifold. The intercepting valves do not disturb the fluid motion in the manifold, since they are to the side of it. It makes the whole manifold better balanced and easier to calibrate. The valves also make the pipes fixation easier because the return pipes don't need to cross behind the flow manifold, as usually happens.

SF

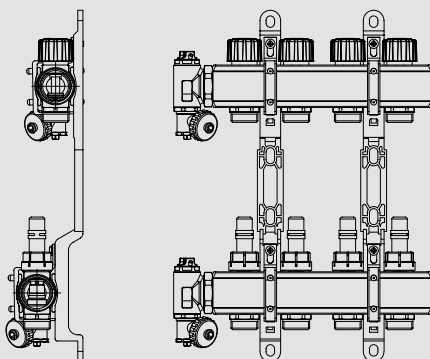
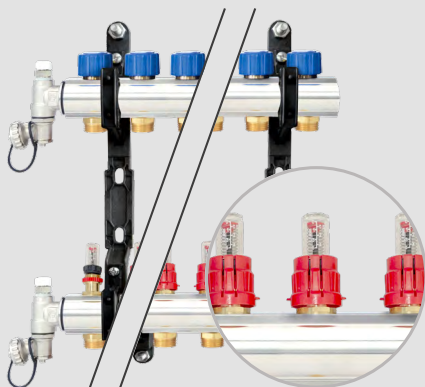

Manifold SF 1"

Nickel plated brass manifold of 1" Series S or SF completed with 2 manual valves for each circuit (EN 1264-4), a drain plug, air vent, ending fittings, brackets to fix the manifold to the wall or into a cabinet. It's prepared for installation of actuators for each circuit.

COMMAND DUO S

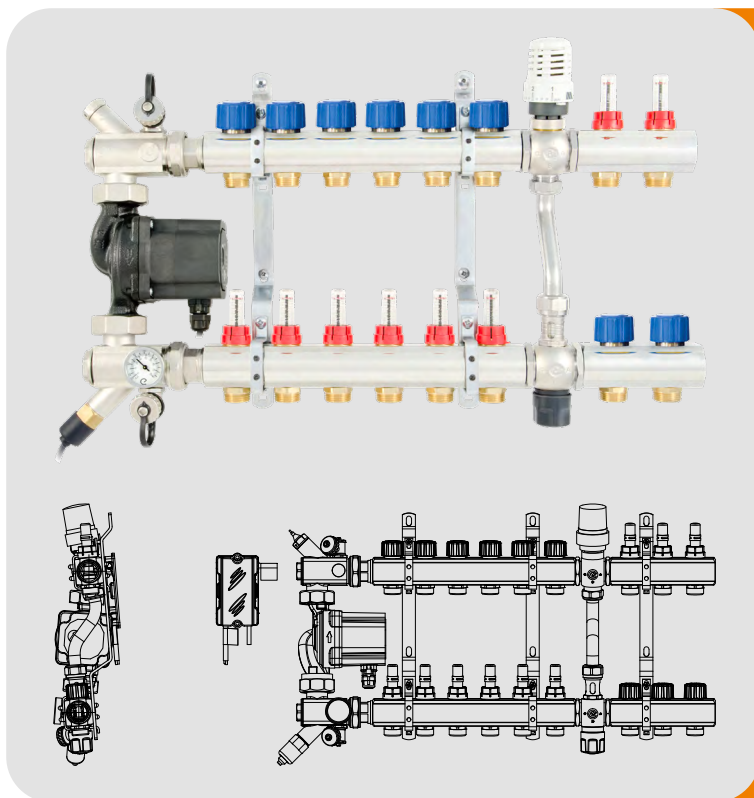

Command Duo S

This is a complete heating and cooling climate regulation system of the fluid circulating in the radiant system based on the external temperature (clima version), or as fixed point version. The Command Duo S is ready to be connected to the serie S-SF manifold and has 1" F attachments to be able to serve a second high temperature system manifold. It works by injecting water from the main circuit.

COMMAND MIX SL

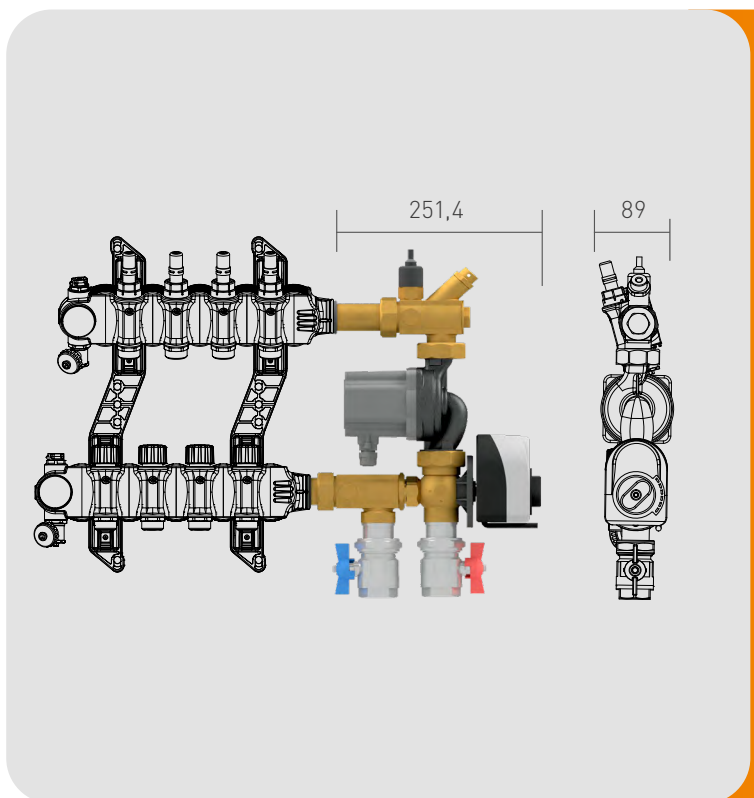

Command Mix SL

Command mix SL is a climate control system equipped with a 3-way mixing valve, designed for adjusting the heat supply to the building's heating requirements and guaranteeing optimal performance in terms of comfort. Flow characteristic of the mixing valve: $K_v=4,5$

- variable speed electronic circulation pump
- 3-way mixing valve
- actuator
- safety thermostat
- electronic delaying device

COMPAMAT

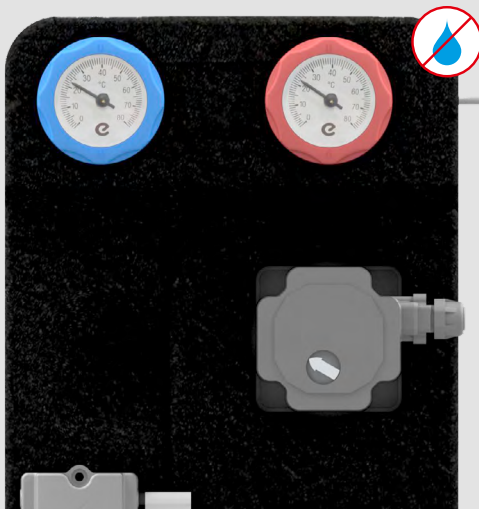

Casing specially designed for preventing heat dispersion during heating and condensate build-up during cooling.



Possibility of installing the regulation unit horizontally or vertically.

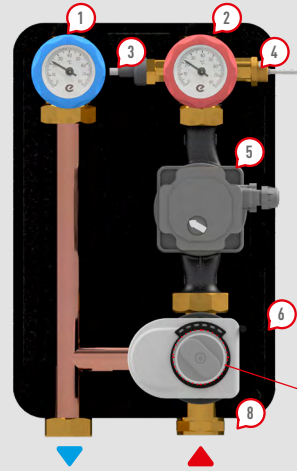

1. return thermometer with ball valve
2. delivery thermometer with ball valve
3. safety thermostat with delay
4. delivery probe sump
5. electronic circulator pump
6. polypropylene cover
7. three-way mixer valve
8. couplings $\varnothing 1\frac{1}{4}$ with seal

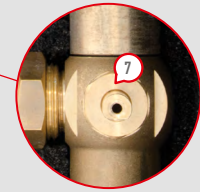

Regulation units

Regulation unit for managing the radiant system at low temperature during heating and cooling, with poly-propylene insulating casing. The variable-speed pump is a circulator with permanent magnet synchronous motor controlled by an inverter with 230 VAC supply voltage at 50 Hz frequency and min. 3 W / max. 225 W consumption. The servo motor can receive a three-point command, has a stroke (open/close) time of 120 sec, 230 VAC power supply at 50 Hz frequency and 8 W consumption. The mixing valve has a rotating spherical element for optimising mixing precision. Suitable for installation in central heating units and installable both horizontally or vertically.

R

Flow rate 1850 l/h
Heating surface
185 m²
Hp. $\Delta t = 6^{\circ}\text{C}$,
P=70 W/m²
Circulator EEI \leq 0,20



TOP

Flow rate 4000 l/h
Heating surface
400 m²
Hp. $\Delta t = 6^{\circ}\text{C}$,
P=70 W/m²
Circulator EEI \leq 0,23



SUPER

Flow rate 6000 l/h
Heating surface
600 m²
Hp. $\Delta t = 6^{\circ}\text{C}$,
P=70 W/m²
Circulator EEI \leq 0,23

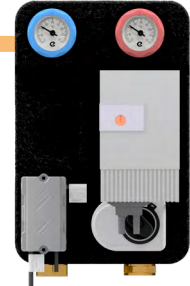

VERTICAL FIX POINT

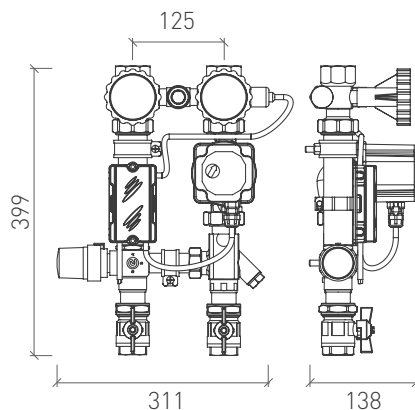
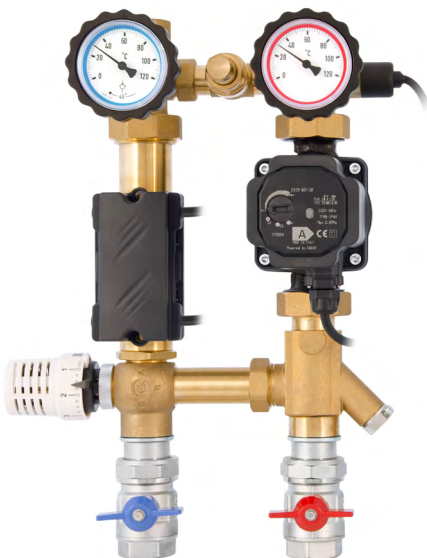

Components:

- variable speed electronic circulation pump (energy efficiency EEI < 0,27)
- safety thermostat
- electronic delaying device
- thermostatic valve (fixed point)
- bypass
- inlet/discharge valves

Flow characteristic of the derivation valve: $K_v=1,3$ (fixed point)

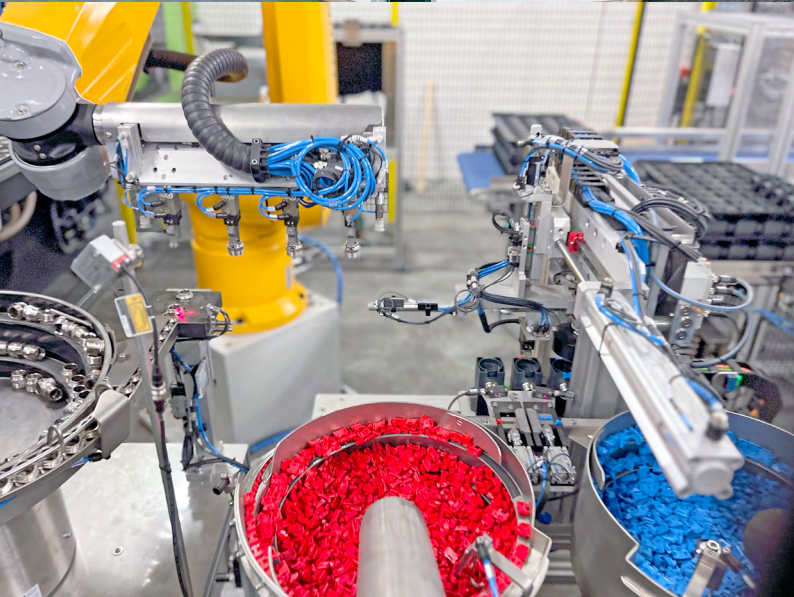
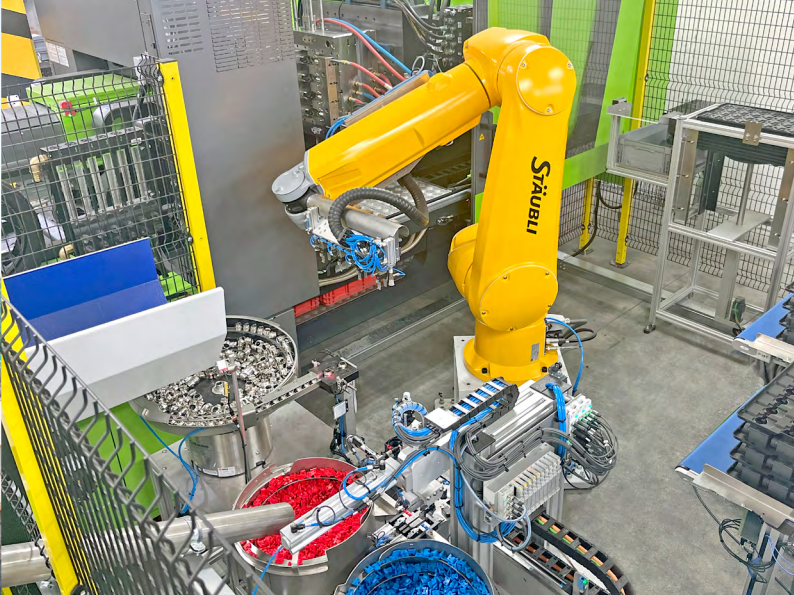

PRODUCTION PLANT BOLZANO/BOZEN (ITALY)

Enetec SpA Benefit Company

Pillhof 89
I-39057 Frangarto (BZ)
T +39 0471 051 508
F +39 0471 051 509
mail@enetec.info

Enetec GmbH

International sales
Kalkarer Str. 81 – Halle 26
D-47533 Kleve
T +49 2821 89 88 00
sales@enetec.info

Plant Bolzano/Bozen

Molding & Milling
Pillhof 89
I-39057 Frangarto (BZ)
T +39 0471 051 508
F +39 0471 051 509
mail@enetec.info

Enetec Plastics GmbH

Pipe extrusion
Kalkarer Str. 81 – Halle 25-27
D-47533 Kleve
T +49 2821 89 88 00
pipes@enetec.info

Plant Verolanuova

EPS Production
Via IV Novembre, 34
I-25028 Verolanuova (BS)
T +39 030 933163
F +39 030 9923998
eps@enetec.info